

## Introduction

ReCover is a Not-for-Profit in Halifax, NS that is planning to increase the energy efficiency of buildings, using Deep Energy Retrofits. This involves replacing inefficient mechanical systems, adding solar energy, and insulating the exterior of the building with new prefabricated wall panels. The production of these wall panels is a significant feat, because the panels are as large as **35x9x1 ft and 2500 lb.**



(Pearce, 2018)



(ReCover, 2021.)

## Design Requirements

- Design a method to lift and move panels within the assembly facility, ensuring safe rigging conditions.
- Design a solution for holding a panel in the vertical position during assembly, while allowing workers to access the faces of the panel.
- Design a solution for storing 35 panels within the facility, and they cannot be stored horizontally (stacked).

## Design Process

### Initial Phase

- Gantry designs were explored as a method for lifting.
- Assembly table on casters to be used for moving the panels and as a worksurface during panel assembly.
- Storage solution explored using straps to bundle panels.

### Scope Changes

- Decided that a forklift should be used for lifting so it could also be used for moving other materials in the facility.
- Identified that the panels should be held vertically during assembly, for more efficient production.
- Safety concerns regarding storage led to the pursuit of a prefabricated structure with a certified load capacity.

### Final Phase

- Selection of forklift and lifting/rigging attachments.
- Selection of support for vertical position.
- Selection of storage structure.

## Design Solutions

### LIFTING AND MOVING

#### Hercules SLR 10' Spread Lifting Beam

- Vertical connection to panel, minimizing panel internal stress.
- Minimizes headroom.



(Hercules SLR Inc., 2021)

#### Lift-N-Tow Attachment 1390B

- Attaches to forks for vertical lifting, minimal headroom.



(Star Industries, 2021)



(Hyundai Forklift, 2015)

#### Hyundai 30L-7A Forklift

- 6000 lb standard capacity.
- 3500 lb derated capacity with modified load center from Lift-N-Tow attachment.
- Max fork height of 185 in.

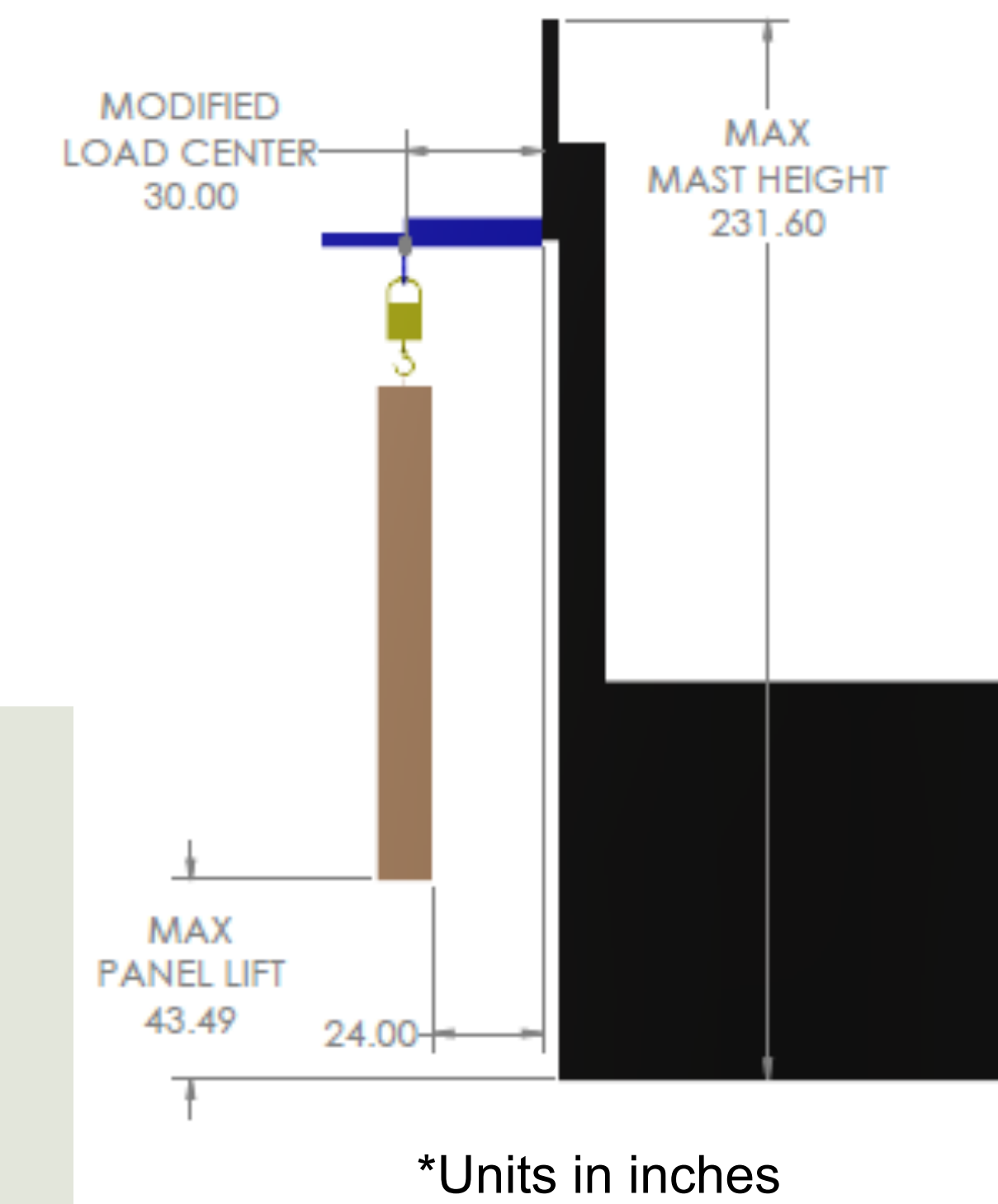
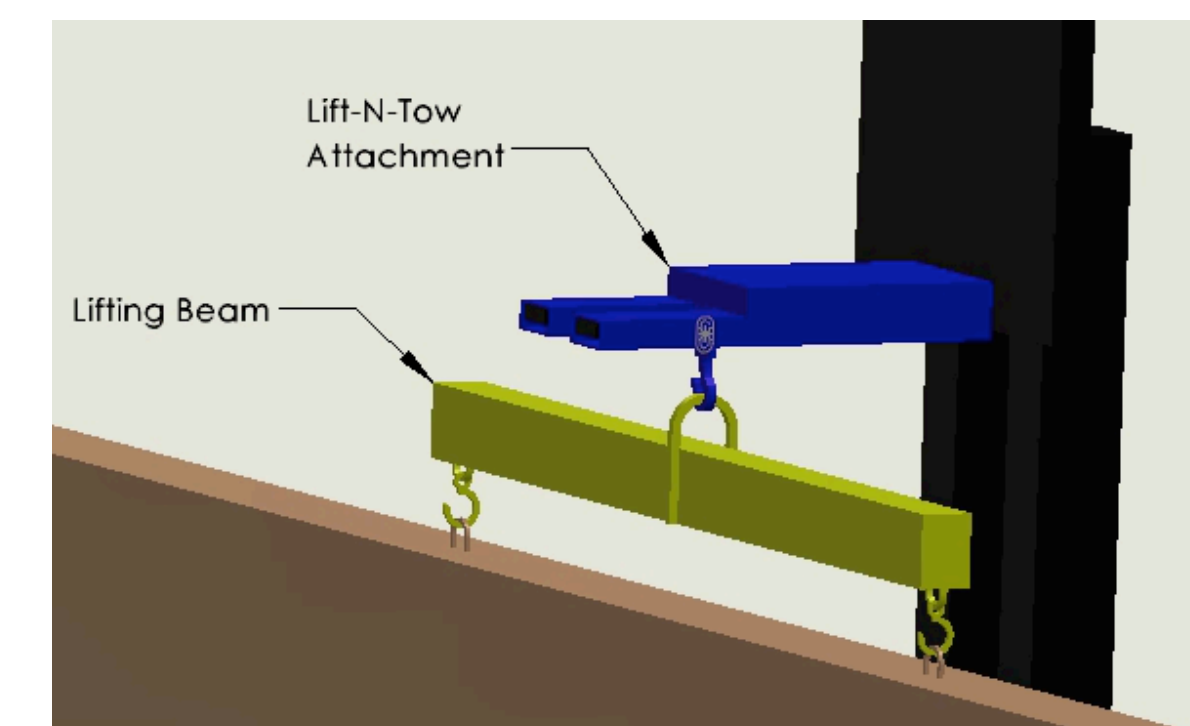

### VERTICAL POSITIONING

#### Design 1: Turnbuckle



(Fab-Form, 2021)

#### Pros:

- Low cost \$24 each
- Light weight and small

#### Cons:

- No strength ratings
- Need multiple
- Not a simple setup

#### Design 2: Wooden A-Braces

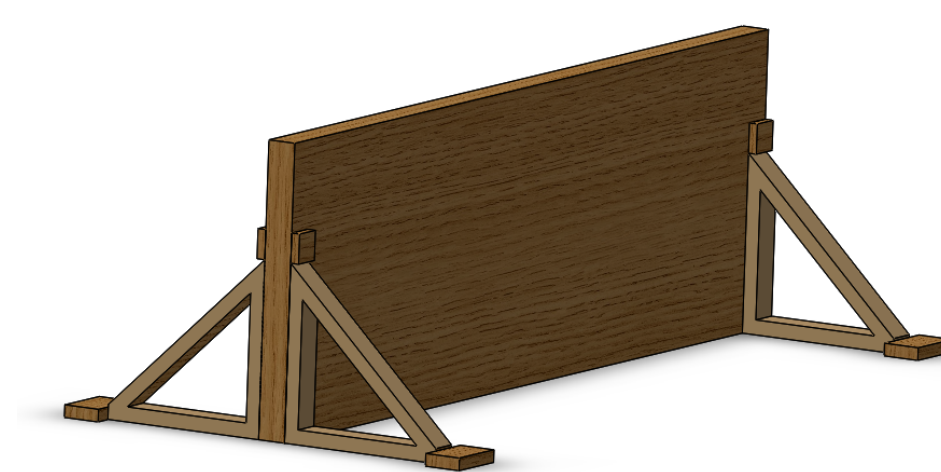

#### Pros:

- Low cost
- No shipping, bought locally
- Wood easily modified

#### Cons:

- Large and heavier
- Covers worker space
- Requires facility space

#### Design 3: Tilt-Up Wall Brace

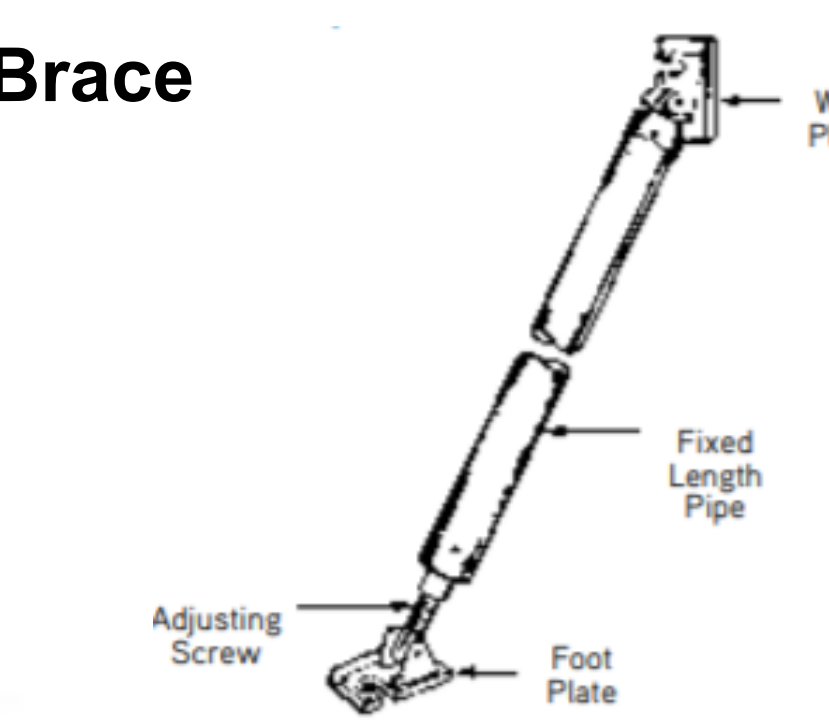
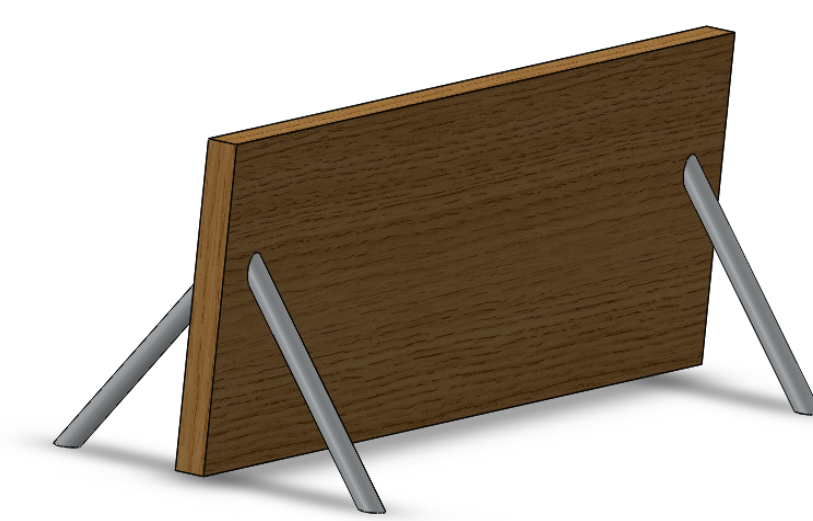

(Dayton Superior, 2021)

#### Pros:

- Light weight and small
- Rated Ultimate Load of 10,000 lb
- Easily adjustable
- Safest option
- Doesn't take space away from workers

#### Cons:

- Need Deadman bolt connections or Helical Ground Anchor
- Need to be shipped
- Not a simple setup
- High cost \$390 each

### STORAGE

#### Aardwolf Slab Rack

- 117 inch base rails, bolted to the ground.
- 63 inch adjustable posts.



(GranQuartz, 2021)

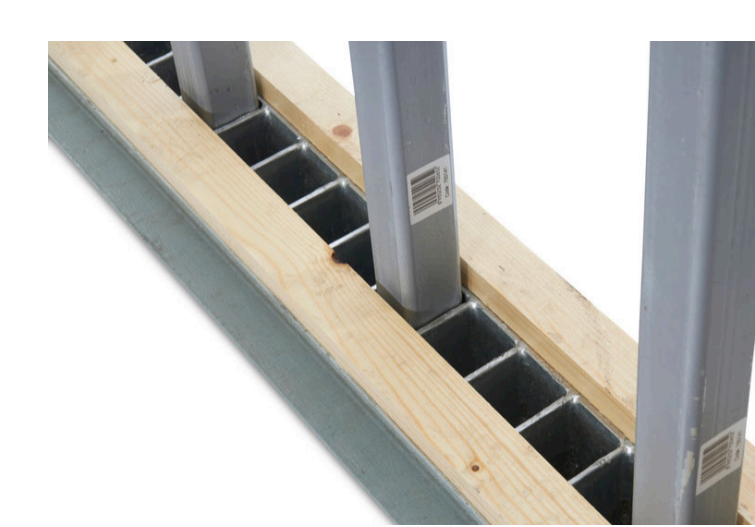

(GranQuartz, 2021)

- Each set of 2 rails can fit 6 panels.
- Each set of 2 posts is rated for 9400 lb capacity (4700 lb capacity per post).

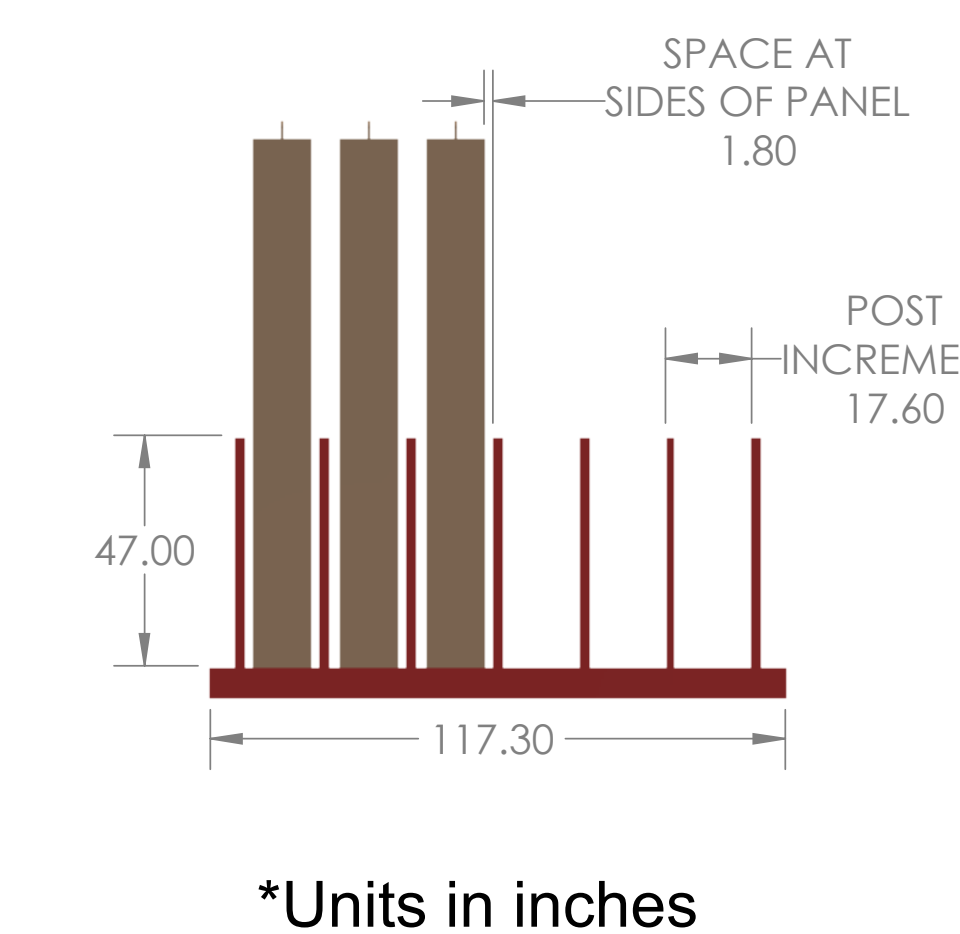
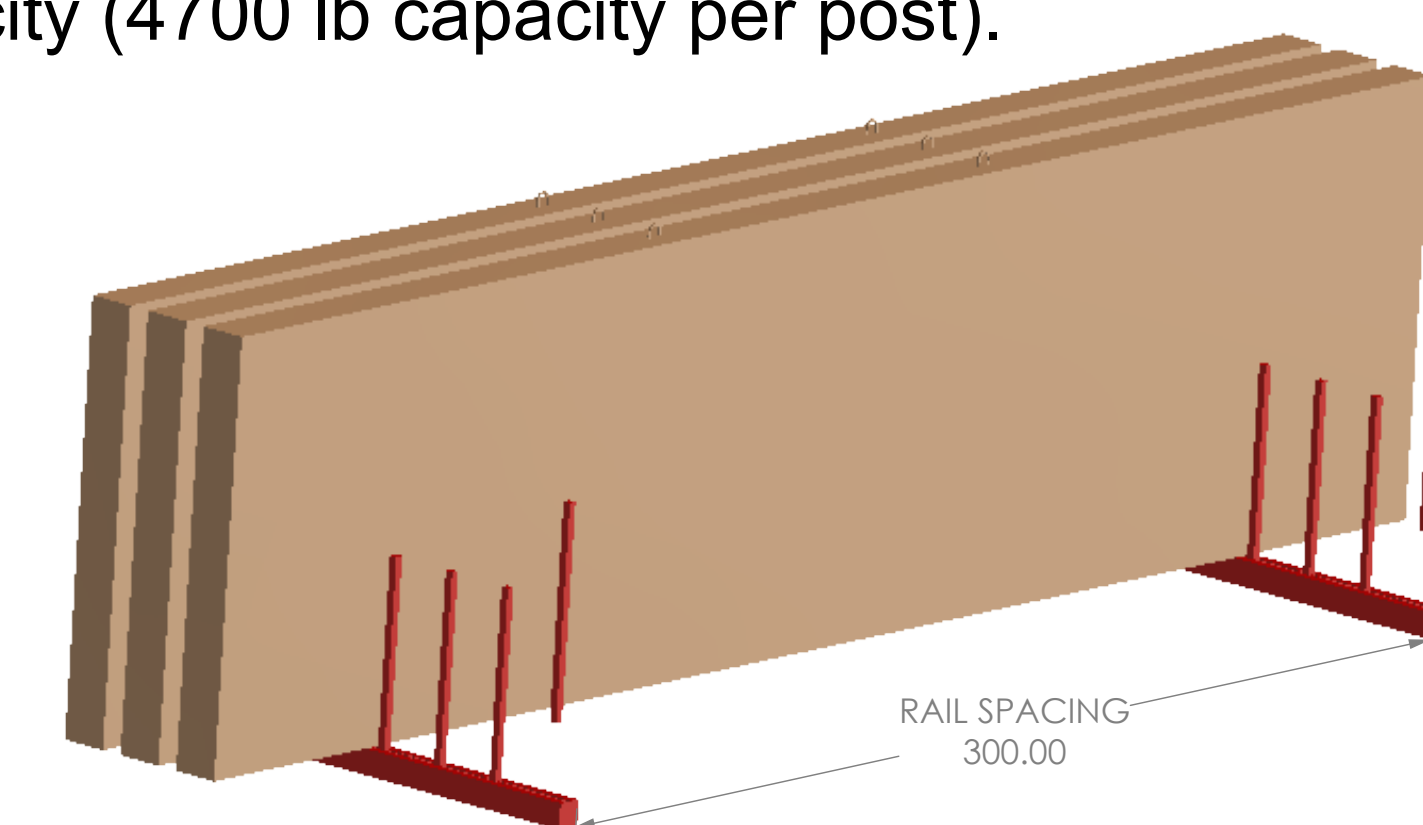

## Budget

Item	Qty	Unit Price	Cost	System Cost
<b>Forklift/Rigging System</b>				<b>15,604.07</b>
Hyundai 30L-7A Forklift, 1 Month Rental w. ins.	6	1,804.79	10,828.72	
Forklift Delivery Fee (HRM), 1 Way	2	230.00	460.00	
Forklift Fuel, 1 Tank (4-8 hr operation)	10	80.50	805.00	
Lift-N-Tow Attachment 1390B	1	1,099.77	1,099.77	
Hercules SLR 10' Spread Lifting Beam	1	2,410.58	2,410.58	
<b>Forklift/Rigging Training</b>				<b>1,023.50</b>
Hercules SLR Forklift Certification, 1 person	2	224.25	448.50	
Hercules SLR Rigging Certification, 1 person	2	287.50	575.00	
<b>Vertical Position System</b>				<b>1,794.00</b>
ARROW Tilt-Up Wall Brace BA0508R	4	448.50	1,794.00	
<b>Storage System</b>				<b>13,844.09</b>
Aardwolf Slab Rack Base Rail 118"	12	638.24	7,658.86	
Aardwolf Slab Rack Post 63"	84	62.61	5,258.90	
Shipping Charges	1	926.32	926.32	
			<b>Total Cost</b>	<b>\$32,265.66</b>

- Budget does not include labor associated with setting up the systems, or costs for smaller items such as attaching hardware, tag-lines for rigging, etc.

\*Taxes included in prices.

\*Forklift rental prices likely to fluctuate before build starts.

\*Supplier references available upon request.

## Deliverables for ReCover

- Standard Operating Procedures for lifting/moving panels, securing panels with vertical positioning, storing panels.
- Discussion of safety considerations and hazard mitigation.
- Project Budget.
- Recommendation and discussion of future considerations (design variations & additional key project planning).

## Future Plans and Considerations

- Further analysis of wooden A-Brace vertical supports, potentially consider as alternative to Tilt-Up Wall Brace.
- Consider Forklift purchase instead of rental, depending on project scope after the pilot build is completed.
- Plan of facility layout, accounting for assembly area, panel storage area, material storage area, workshop area, etc.

## Acknowledgements

Thank you to Dr. Cliff Johnston and Holly Pharoah for your guidance, Dalhousie Technicians for providing design feedback, Department of Mechanical Engineering for project sourcing and Nick Rudnicki, Director of ReCover for guidance and technical insight throughout the project.